

DOC NO	ISSUE	REVISION	PRODUCT REF.	DATE	QUALITY PLAN
03.05	0	01	PN-02	15.03.06	
<b>TECHNICAL SPECIFICATIONS</b>				<b>SIGNATURE</b>	
				<b>PRESIDENT</b>	

## WORK POSITIONING BELT (PN-02)

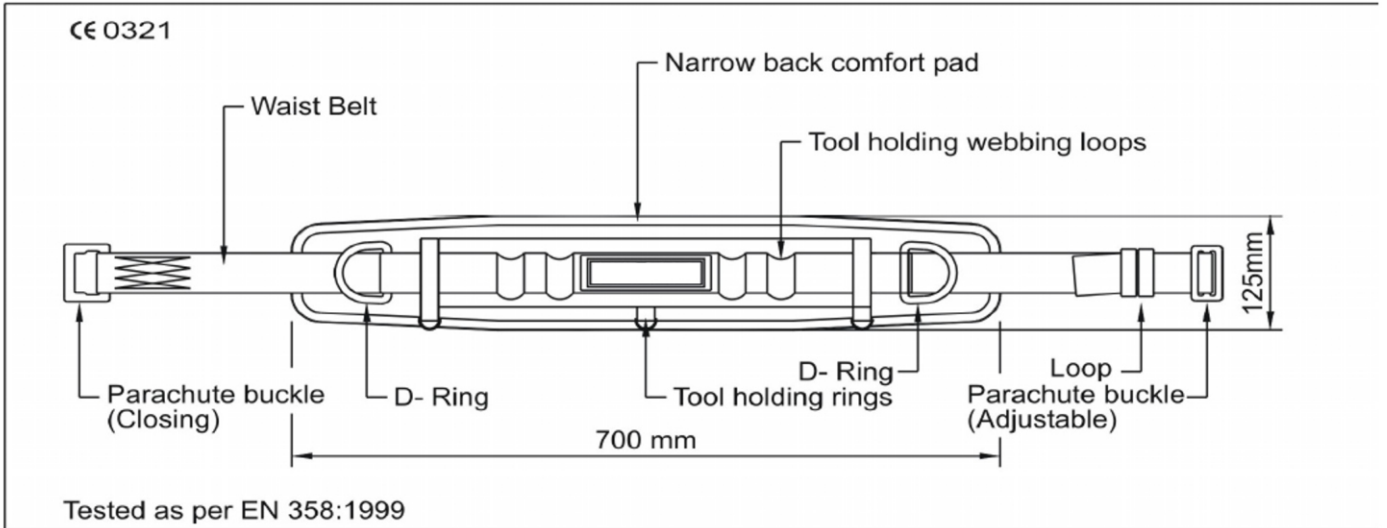

### DESIGN

- Two lateral attachment D-ring at waist positioning
- Narrow comfort pad made of foamed EVA with textile on both sides.
- Waist belt can slide over comfort pad freely.
- Tool holding loops for holding tools
- Ring for tool bag holding.

### WEBBING

- Material : Polyester
- Width : 44±1mm
- Breaking strength: 30 KN or 3,060 kgf (Min)

### STITCHING THREAD

- Material : High-tenacity polyamide
- Colour : White

### METAL COMPONENTS

- Material : Steel
- Plating : Zinc plating
- Finish : Deburred & Polished.

### VITAL TEST COMPLIANCE

- Static Strength : 15 KN or 1,530 kgf for 3 Minutes at each attachment element.
- Dynamic strength: Free fall from 1 meter height donned to a test dummy weighing 100 kg at each attachment.

### WEIGHT

- : 530 gm ±10%