

DOC NO	ISSUE	REVISION	PRODUCT REF.	DATE	QUALITY PLAN
QF/RD/05	01	00	AKTESS035	06.01.15	
TECHNICAL SPECIFICATIONS				SIGNATURE	
				PRESIDENT (TECHNICAL)	

RETRACTABLE FALL ARRESTOR (AKTESS035)

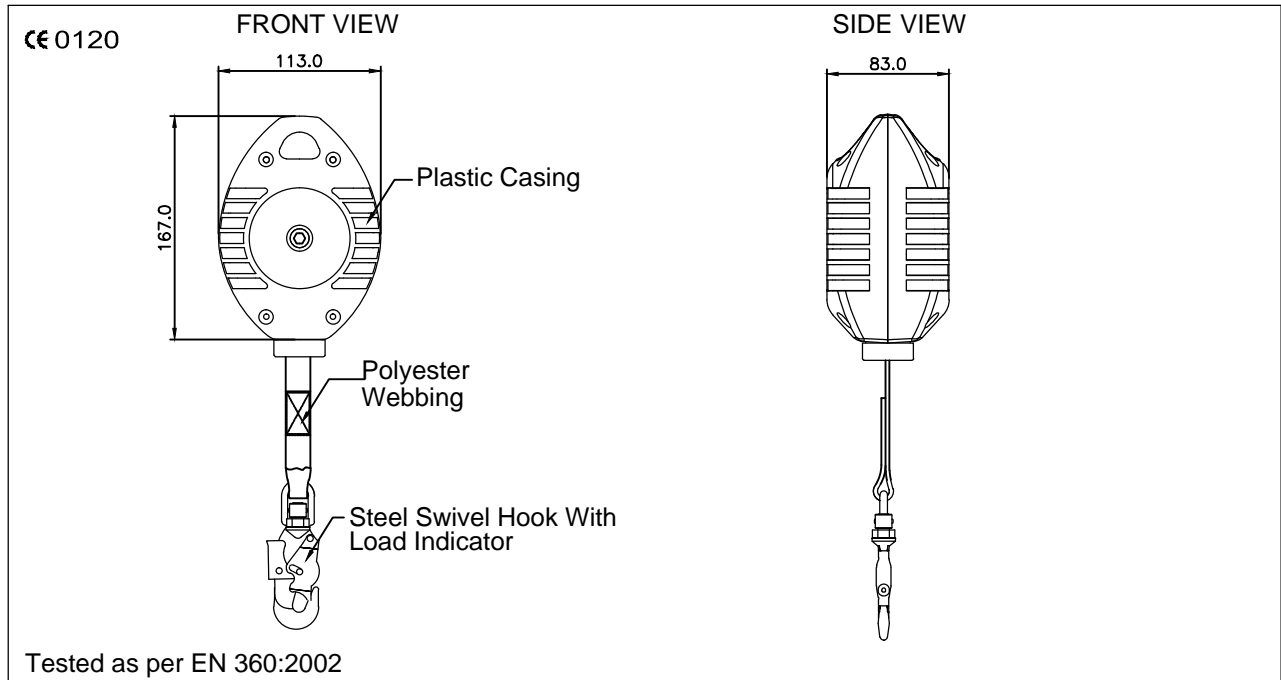

PHYSICAL PARAMETERS

- Robust & durable plastic casing.
- Has anchorage handle at anchorage end.
- Steel swivel hook with Load Indicator our Ref. PN 123 at attachment end.
- Polyester Webbing.

LENGTH

- 3.5 Meters

WEBBING

- Material : Polyester Webbing 25 mm.
- Breaking strength : 17 KN or 1,735 kgf (Min.)

VITAL TEST COMPLIANCE

- Static Strength : 15 kN for 3 Minutes.
- Dynamic Performance : 100 kg mass free fall with the breaking force of less than 6 kN & arrest distance less than 2 mts.

NORM

- Meets EN-360:2002

WEIGHT

- 1.53 kg \pm 0.02 kg